

**Standard Construction and Materials**

**FRAME:** 18-GA. galvanized steel.

**BLADE:** 18-GA. galvanized steel. Blades approximately 6<sup>9</sup>/<sub>16</sub>" on centers.

**SCREEN:** (When indicated)  
1/2" mesh, 19-GA. galvanized steel (.041").

**CONSTRUCTION:** Riveted and/or welded, full jambs with blades, head and sill contained within.

**Options**

Flange Frame available.

Finishes - Enamels, Epoxies, etc.

Material - 304 or 316 Stainless steel

Screens - Insect screen 1/4" aluminum mesh,

- or- 1/2" flattened aluminum, .051",
  - or- 1/4" sq. mesh, 18-GA galvanized steel, .047",
  - or- 1/2" sq. mesh, 18-GA stainless steel, .047",
- Others available.

**Notes**

1. 1/2" nominal deduction will be made to the opening size given.
2. Approximate shipping weight is 8.5 lbs./sq.ft.

**Louver Sizes**

Min Panel	Max Single Panel
12"W x 12"H	60"W x 96"H

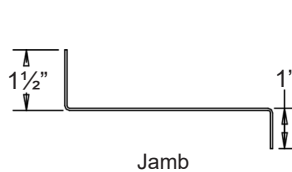
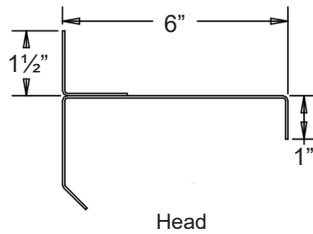
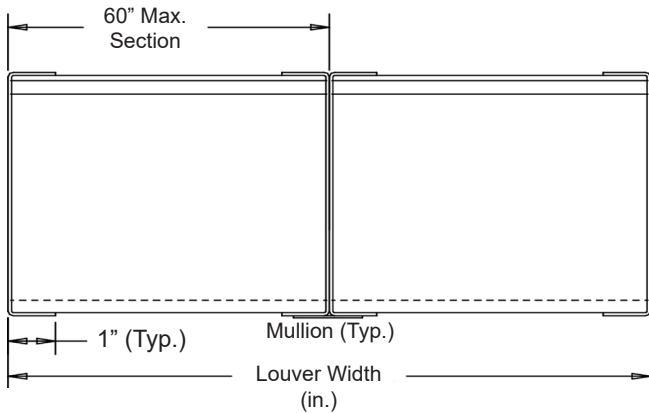

Flange Frame Available

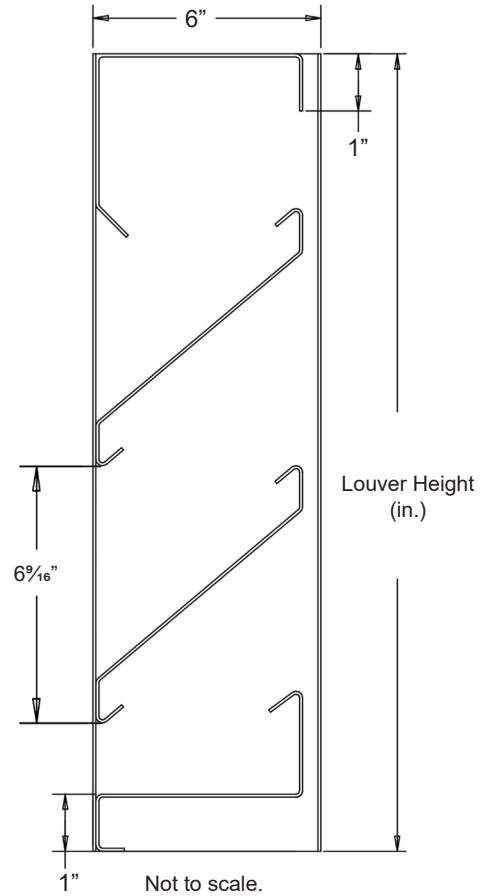
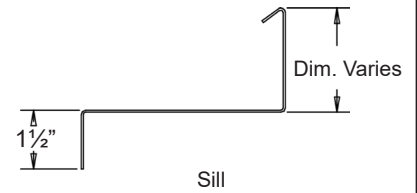

Item #	Qty	Width	Height	Width	Height	Mullion	Type	Location		
		Opening Size		Louver Size			Screens			Union Made
Arch. / Eng.:						EDR:		ECN:		Job:
Contractor:										
Project:						Date:		DWN:		DWG:

In the interest of product development, Cesco Products reserves the right to make changes without notice.



450 Riverside Dr • Wyalusing PA, 18853  
 Phone: 570-746-1888 • Fax: 570-746-9286  
 www.cescoproducts.com

Free Area Table

Free Area (sq.ft.)

		Width (in.)								
		12"	18"	24"	30"	36"	42"	48"	54"	60"
Height (in.)	12"	.19	.31	.42	.53	.65	.76	.88	.99	1.11
	24"	.56	.89	1.23	1.56	1.90	2.23	2.57	2.90	3.24
	36"	1.05	1.68	2.31	2.94	3.56	4.19	4.82	5.45	6.08
	48"	1.61	2.58	3.54	4.51	5.48	6.44	7.41	8.38	9.34
	60"	2.17	3.48	4.78	6.09	7.39	8.69	10.00	11.30	12.61
	72"	2.71	4.33	5.95	7.58	9.20	10.83	12.45	14.08	15.70
	84"	3.17	5.08	6.98	8.89	10.79	12.69	14.60	16.50	18.40
	96"	3.54	5.67	7.80	9.92	12.05	14.18	16.30	18.43	20.56